



INSPIRING.
TIMELESS.
ENDURING.

INSPIRING. TIMELESS. ENDURING.

At Realstone Systems we offer limitless design possibilities with the largest high quality stone veneer product line in the industry.









Sierra Accentstone Panels



WE SWEAT THE DETAILS SO YOU DON'T HAVE TO.

At Realstone Systems™, we pride ourselves on offering the largest selection of top quality natural stone cladding in the industry. And we back it with unparalleled service and support. Realstone stands for consistent quality, integrity, timeless beauty and most of all, endless possibilities.



DIMENSIONS

consistent sizing

Each panel is made to adhere to our stringent quality standards. The result is consistent sizing, no gaps, straight edges and a beautiful installation.



COLOR

stringent color lots and tolerances

Each stone in every Realstone panel is hand selected to fall within our stringent color variance, then sorted by lot for beautifully blended coloring with no checkerboarding.

SPEC & DESIGN TOOLS

spec docs, hatch patterns, Web Gallery

We have the design tools to support everyone from professional designers to first time dreamers. For more inspiration and design docs, explore our Web gallery and social pages or call us, we'd love to help.



TESTING

ASTM, Installation Partner support

Our products have gone through rigorous testing and meet nationally set standards for quality. For installation and care support we have partnered with select manufacturers.



CUSTOMER SERVICE

we're happy when you're happy

We believe a quality product is only as good as the people who care and believe in it. That is why our close knit team of sales and support staff is always happy to answer questions and provide the support materials you need. We can be reached by phone, email, social media and live chat on our website.

PACKAGING

well packaged for safety and convenience

Our products are optimally packaged for convenience and protection from damage during transportation and on the job site. Less breakage means less waste.



GREEN

recycled raw materials

Many of our products contain pre-consumer recycled content, providing green benefits and possible LEED points. Ideal for those looking to incorporate responsible products into their projects.

THE BEST PROJECTS START WITH REALSTONE.

Not all stone veneer is created equal and with our focus on quality, innovation and customer service we will delight you every step of the way. A high quality product makes a big difference during installation by reducing waste and time which is why many installers will only install stone veneer products made by Realstone. Realstone quality starts at the quarry and ends with gorgeous stone veneer projects.



Portugal Area Panels

ARCHITECTURAL APPLICATIONS

COMMERCIAL

Education P.12

Health Care P.13

Hospitality P.14-15

Municipal P.16

Commercial Landscape P.17

Retail P.18

Commercial Interiors P.19-20

RESIDENTIAL

Residential Interior P.21-23

Residential Exterior P.24

Residential Hardscape P.25

STONE VENEER PRODUCTS

Alesio Collection P.26-27

Plank Tiles P.28-29

Realstone Collection P.30-31

Classic Series P.32-37

Thinstone Series P.38-39

Estate Stone P.40-41

Portugal Collection P.42-43

Hive Collection P.44-45

Antique Wood Collection P.46-47

Realstone Solutions P.48-49

Architectural Accents P.50

PRODUCT SPECIFICATIONS

Spec Chart P.51

Resources

Available at www.realstone.com

TECHNICAL DATA

ASTM Testing

Materials Safety Data

Graffiti removal

Leed credit chart

DESIGN RESOURCES

Architectural specifications

Hatch Patterns

Seamless textures

Visualizer

Project Gallery

INSTALLATION GUIDES

Installation product recommendations

Installation tips

Product calculator



Arctic White Shadowstone Panels

Photo: Vincennes University- Y Factor Studios



photo: Dirk Van Den Muijsenberg-Face Skincare Medical Wellness Spa

White Birch Honed Panels, Corners

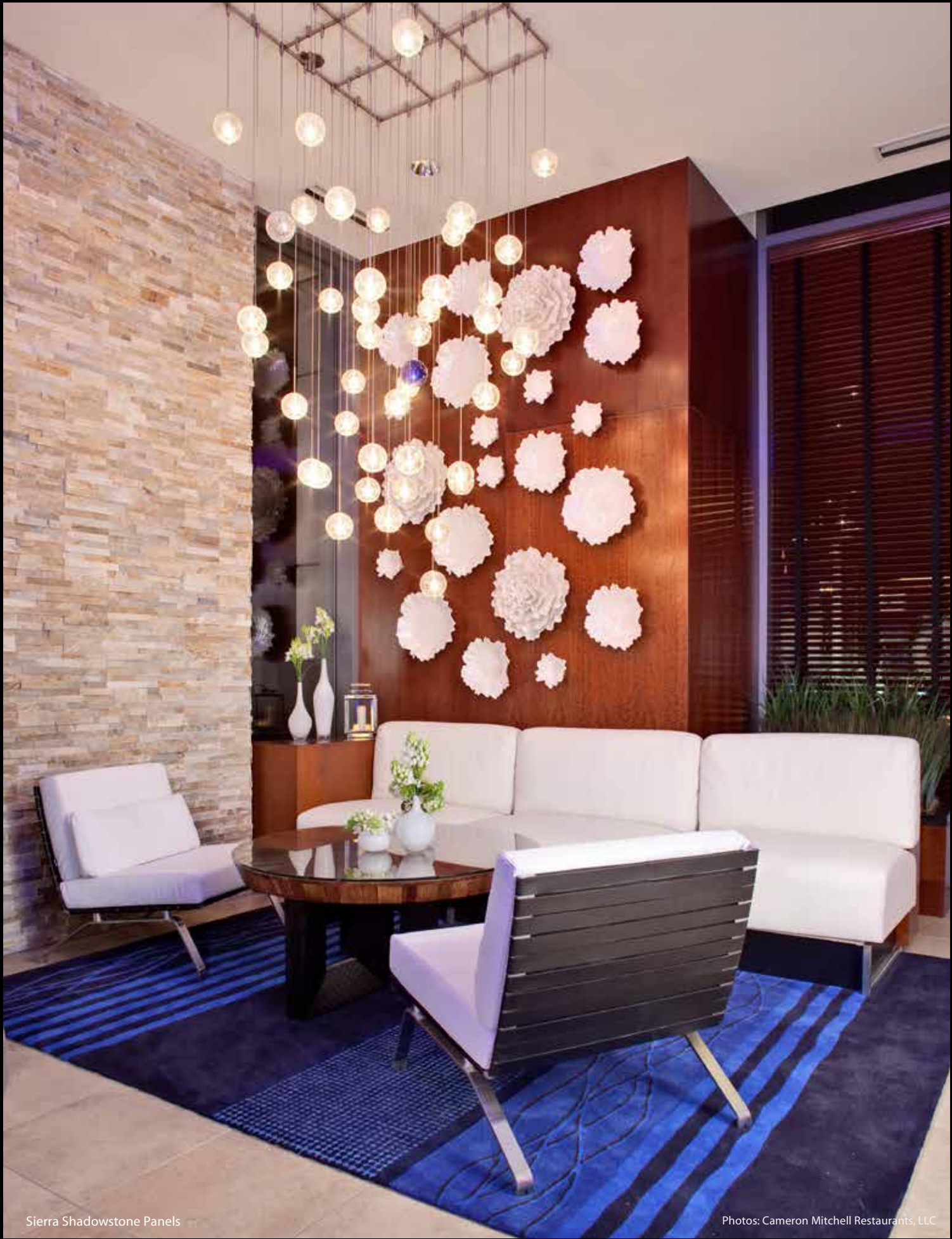

Sierra Shadowstone Panels

Photos: Cameron Mitchell Restaurants, LLC



Arctic White Shadowstone Panels, Corners



Charcoal Thinstone Panels, Corners



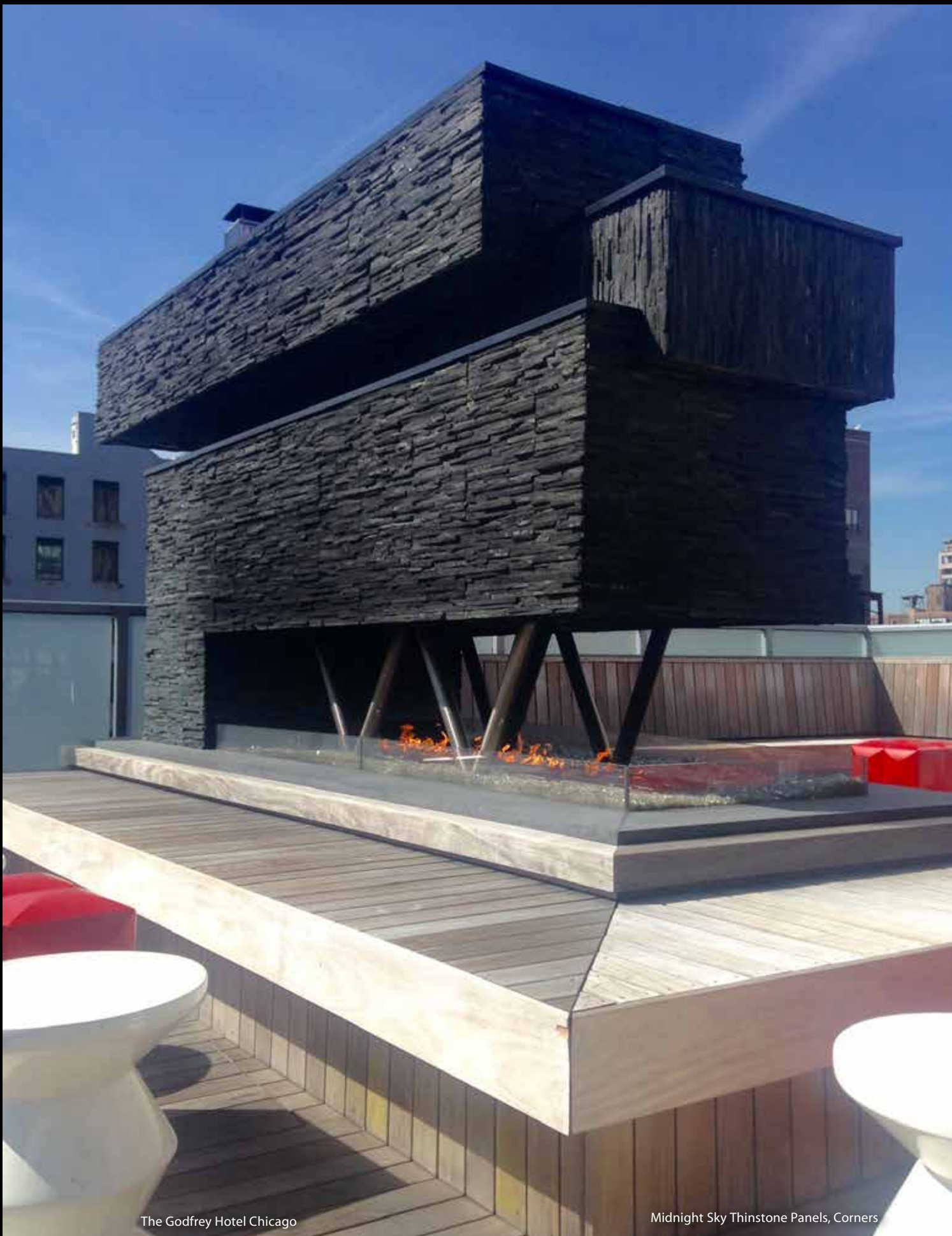

The Godfrey Hotel Chicago

Midnight Sky Thinstone Panels, Corners



White Birch Honed Panels, Corners

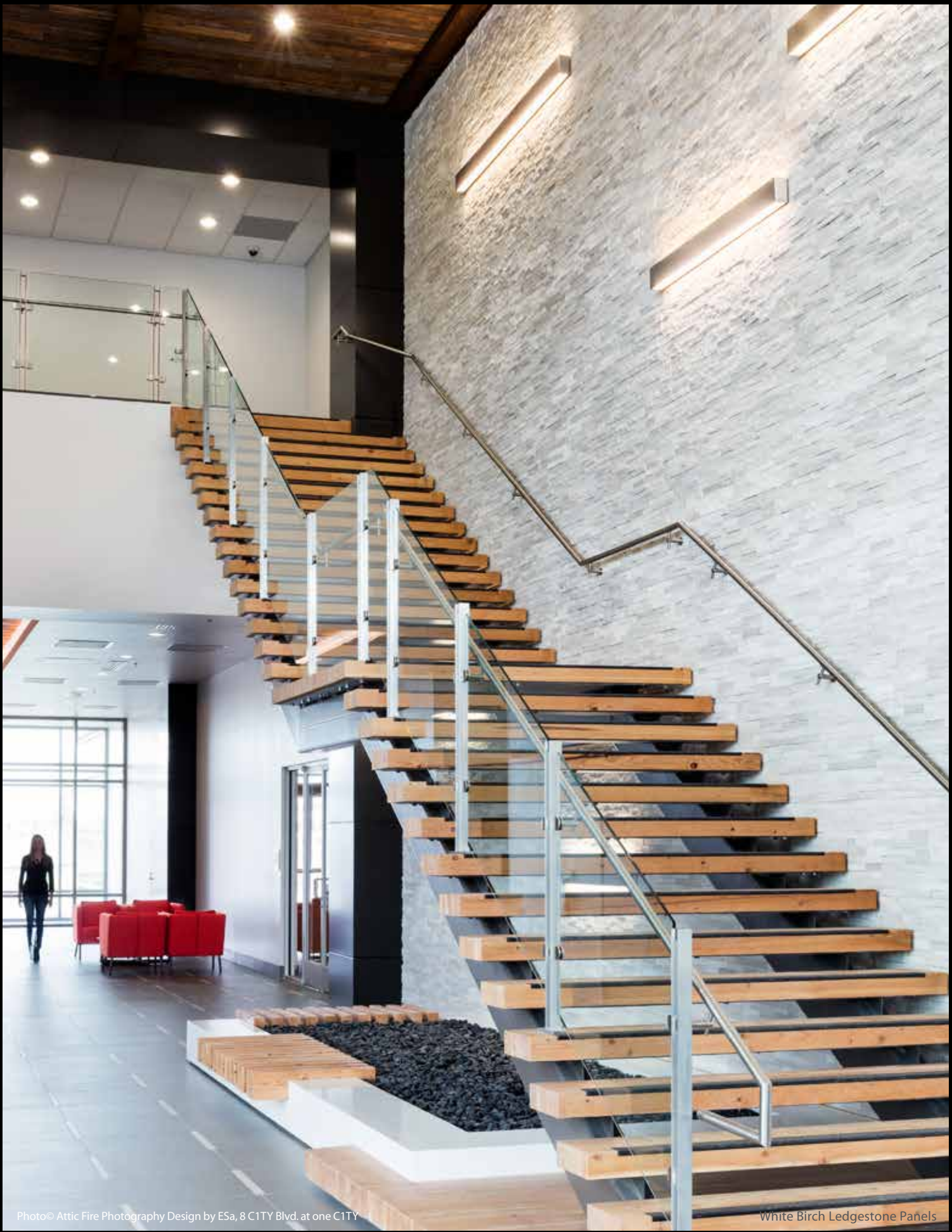

Photo© Attic Fire Photography Design by ESa, 8 CITY Blvd. at one CITY

White Birch Ledgestone Panels



Greystone Gold Estate Stone Panels, Corners

Design: Interactive Studio, Spectrum Health Medical Group Concierge Medicine GR, MI



Hive Chiseled Cream Tiles

SIW Design Group LLC.



Hive Etched Cream Tiles



Award winning design: AMW Design Amy Miller

Silver Alabaster Shadowstone Panels



Bluestone Shadowstone Panels

Stephanie Smith-Classic Designs Unlimited, Calabash NC

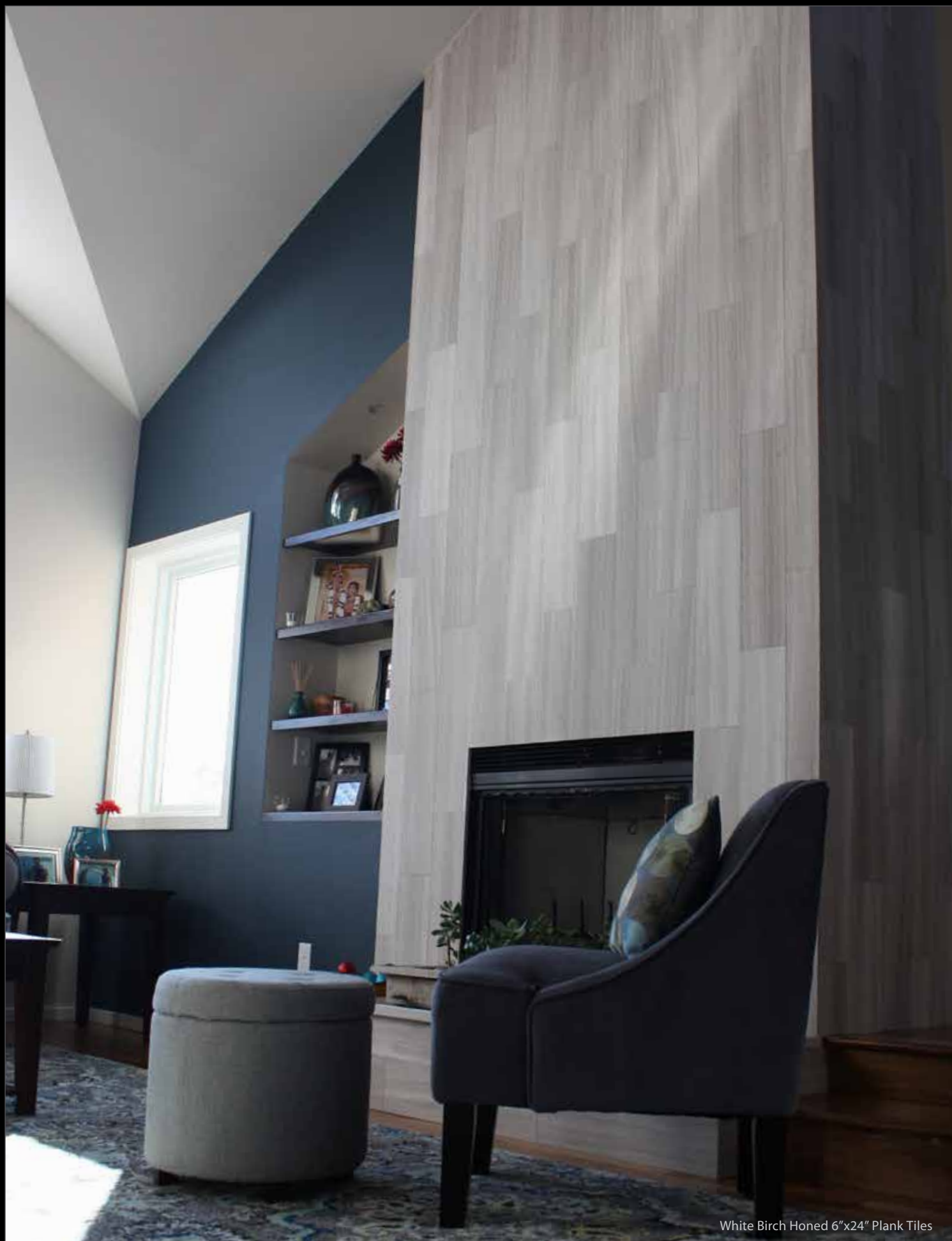

White Birch Honed 6"x24" Plank Tiles



Sierra Shadowstone Panels, Corners

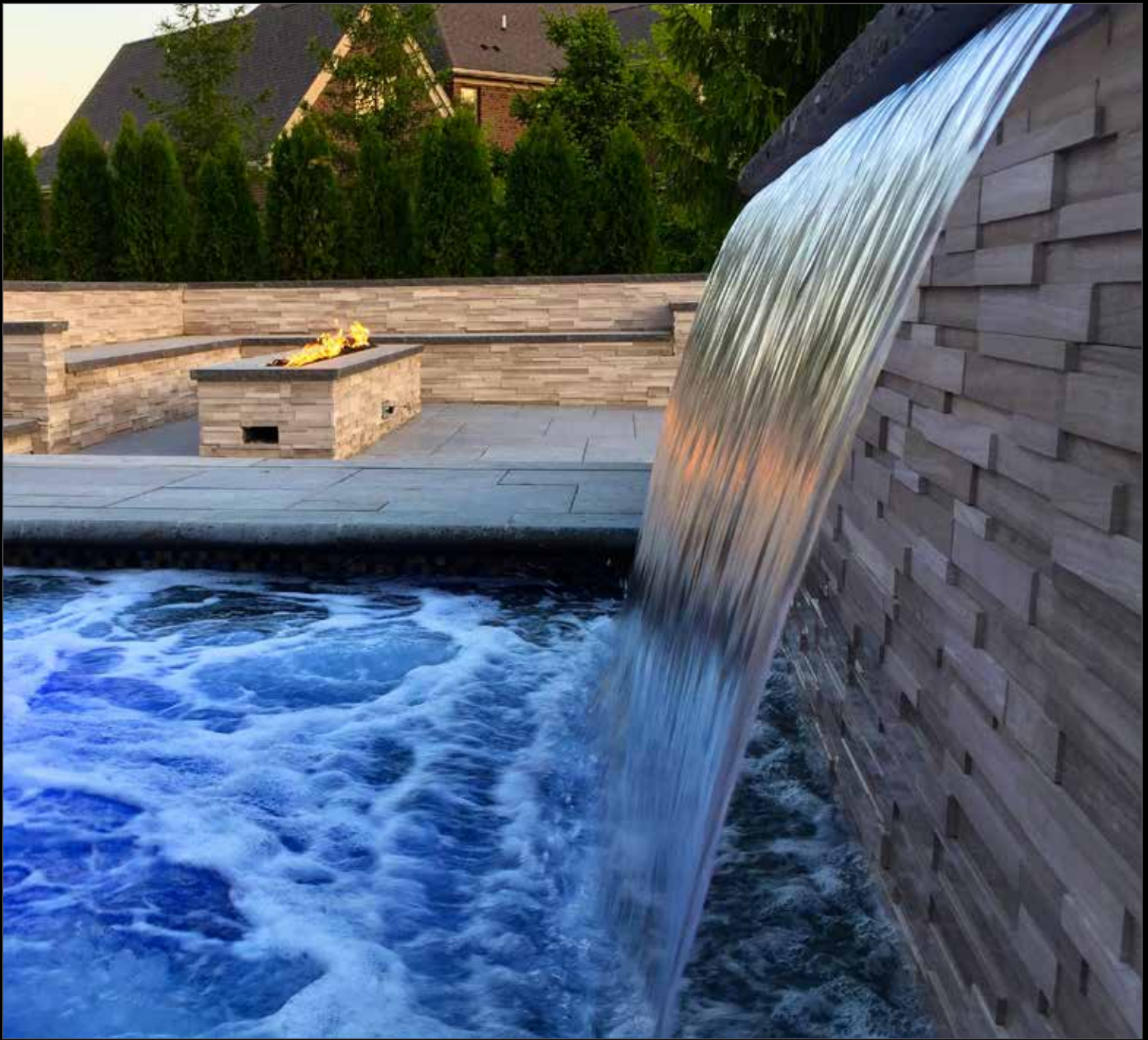

Imagine Landscaping, MI

White Birch Honed Panels, Corners

NEW ALESIO

C O L L E C T I O N



Alesio Spalted Oak Panels, Corners

ALESIO COLLECTION PANELS

The Alesio™ Collection is the latest addition to our ever growing product offerings. Ranging from the exotic wood look of Spalted Oak to the refined neutrals of Creme and Smoky Beige, each unique piece of stone in Alesio brings nature's incomparable beauty to any project.

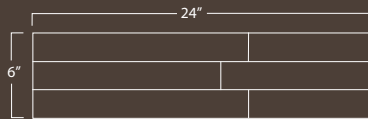

Alesio Pattern

STONE TYPE	Marble, Unfilled Travertine	
AVAILABLE COLORS	Creme, Smoky Beige, Spalted Oak	
FINISH	Honed, Cleft Face	
MATCHING PRODUCTS	Planks, Corners, Hearths	
USAGE	Indoor/Outdoor	
STYLE	Honed	Ledgestone
UNIT SIZE	6" x 24" 1sq.ft. .34-.75" gauge	6" x 24" 1sq.ft. .37-1.00" gauge
AVG. UNIT WEIGHT	8 lbs.	9 lbs
SF. PER BOX	8 sq.ft.	6sq.ft.
PIECES PER BOX	8	6

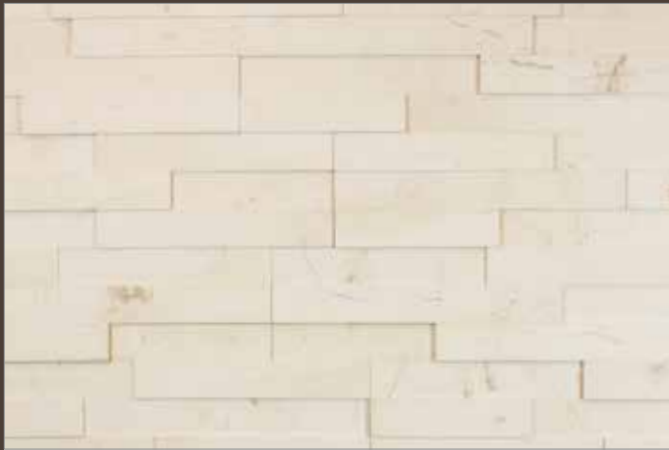

Alesio Creme Honed™ **NEW**



Alesio Creme Ledgestone™ **NEW**



Alesio Smoky Beige Honed™ **NEW**



Alesio Smoky Beige Ledgestone™ **NEW**



Alesio Spalted Oak Honed™ **NEW**

Color variations are inherent in all natural stone products. The product colors you see in this brochure are as accurate as current photography and printing techniques allow. We recommend you look at product samples before you select a color. Pattern illustration is an approximation, actual stone layout may vary.

PLANK TILES



White Birch Honed Planks and Ledgestone Panels, Corners

REALSTONE™ TILE PLANKS

The Realstone™ Tile Planks are our most versatile product with usage as both flooring and vertical cladding. They can be installed in a variety of creative patterns and orientations, including vertical, horizontal, stacked, offset or herringbone. Available in a honed finish in a variety of colors matching our panels and accessories.

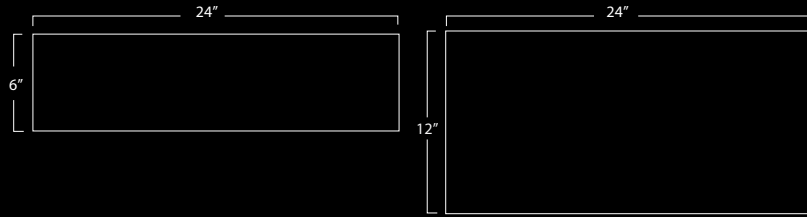

STONE TYPE	Sandstone, Limestone, Granite, Travertine, Unfilled Travertine	
AVAILABLE COLORS	White Birch, Mocha Birch, Nero, Latte, Pewter, Spalted Oak, Creme, Smoky Beige	
FINISH	Honed	
MATCHING PRODUCTS	Panels, Corners, Hearths	
USAGE	Indoor/Outdoor	
UNIT SIZE	12" x 24" 2 sq.ft. 0.4" gauge	6" x 24" 1sq.ft. 0.4" gauge
AVG. UNIT WEIGHT	11lbs.	5-5.5lbs.
SF. PER BOX	5 sq.ft.	5 sq.ft.
PIECES PER BOX	5	10



White Birch™ 6" x 24" and 12" x 24"



Pewter™ 6" x 24" and 12" x 24"



Mocha Birch™ 6" x 24" and 12" x 24"



Latte™ 6" x 24" and 12" x 24"



Nero™ 6" x 24" and 12" x 24"

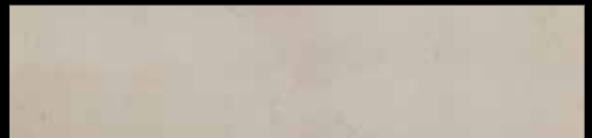

Alesio Creme™ 6" x 24"



Alesio Spalted Oak™ 6" x 24"



Alesio Smoky Beige™ 6" x 24"

INSTALLATION IDEAS





realstone **SYSTEMS**TM
C O L L E C T I O N



Latte Honed Panels, Corners

REALSTONE™ COLLECTION PANELS

The Realstone™ Collection is an exclusive sampling of some of the most beautiful natural stone in the world. Each exquisite panel is crafted to highlight the unique beauty of the stone. Featuring color and pattern combinations only available from Realstone.

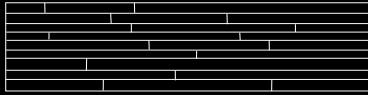

Thinstone Honed pattern

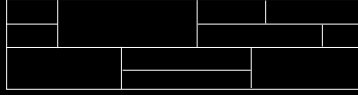

Accentstone Honed pattern

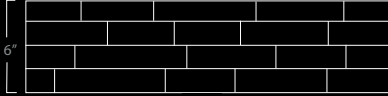

Ledgestone pattern

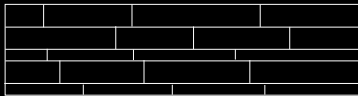

Honed pattern

STONE TYPE	Sandstone, Limestone, Granite, Travertine
AVAILABLE COLORS	White Birch, Mocha Birch, Nero, Pewter, Carbon, Latte
FINISH	Honed, Cleft Face
MATCHING PRODUCTS	Planks, Corners, Hearths, some Ends
USAGE	Indoor/Outdoor
UNIT SIZE	6" x 24" 1sq.ft .4"-1" gauge
AVG. UNIT WEIGHT	9lbs.
SF. PER BOX	6 sq.ft.
PIECES PER BOX	6



Carbon Honed™



Carbon Honed Accentstone™



Pewter Honed™



Latte Honed™



Latte Ledgestone™



Latte Honed Accentstone™



White Birch Honed™



White Birch Ledgestone™



White Birch Honed Thinstone™



Mocha Birch Honed™



Mocha Birch Ledgestone™



Nero Ledgestone™



Nero Honed™

Color variations are inherent in all natural stone products. The product colors you see in this brochure are as accurate as current photography and printing techniques allow. We recommend you look at product samples before you select a color. Pattern illustration is an approximation, actual stone layout may vary.

CLASSIC SERIES



Charcoal Shadowstone Panels

SHADOWSTONE™ PANEL

Shadowstone brings a rich, refined look to any project with its subtle split face finish and vast color palette. The variations in stone gauge and finish give each panel just the right amount of texture and cast a variety of shadows that give your installation an interesting depth.

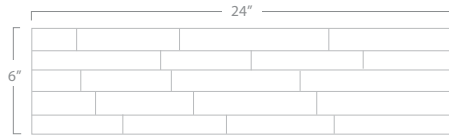

Shadowstone pattern



Chiseled Shadowstone pattern

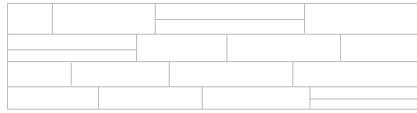

Shadowstone Premium pattern

STONE TYPE	Slate, Quartzite
AVAILABLE COLORS	Silver Alabaster, Arctic White, Bluestone, Charcoal, Chiseled Sea Shell, Terracotta, Midnight Sky, Sierra
FINISH	Split Face, Chiseled
MATCHING PRODUCTS	Corners, Ends, some Hearths
USAGE	Indoor/Outdoor*
UNIT SIZE	6" x 24" 1sq.ft. .4"- 1" gauge
AVG. UNIT WEIGHT	8.5-10.4 lbs.
SF. PER BOX	6 sq.ft.
PIECES PER BOX	6



Silver Alabaster™ P



Arctic White™ P



Bluestone™



Charcoal™*



Chiseled Sea Shell™



Terracotta™



Midnight Sky™ P



Sierra™

Color variations are inherent in all natural stone products. The product colors you see in this brochure are as accurate as current photography and printing techniques allow. We recommend you look at product samples before you select a color. * Moisture may cause this product to rust and effloresce. Pattern illustration is an approximation, actual stone layout may vary.

CLASSIC SERIES

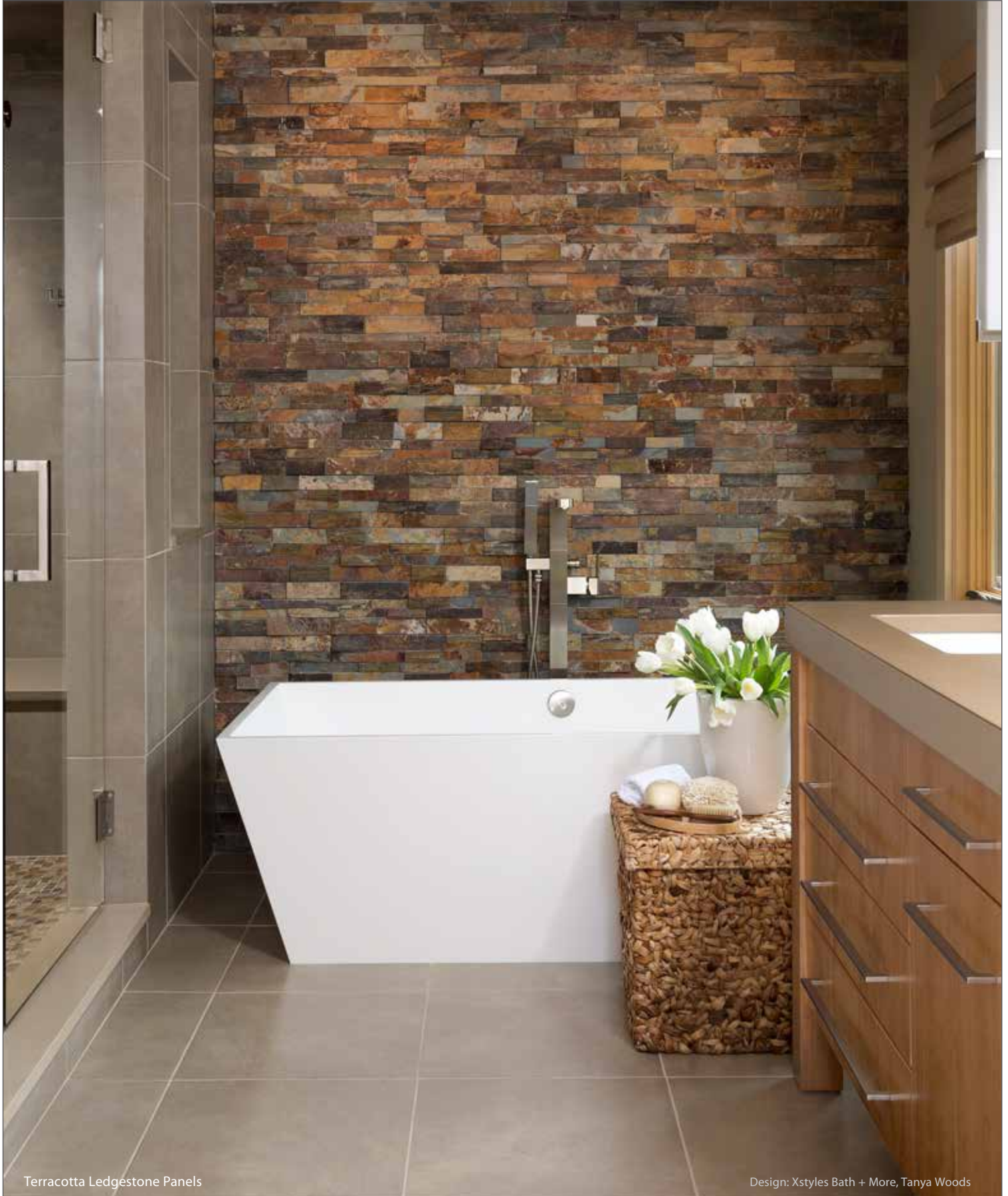

Terracotta Ledgerstone Panels

Design: Xstyles Bath + More, Tanya Woods

LEDGESTONE™ PANEL

Ledgestone™ is a rough cut, cleft face stone with a weathered finish. The varying profiles of the stone give it depth and texture while showcasing the natural beauty of the stone. As the light changes throughout the day, so does the look of the installation, as shadows caress the varying depths of each stone.

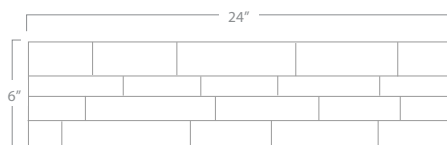

Ledgestone Pattern

STONE TYPE	Slate, Quartzite
AVAILABLE COLORS	Bluestone, Charcoal, Mountain Rust, Terracotta
FINISH	Cleft Face
MATCHING PRODUCTS	Corners, Ends, some Hearths
USAGE	Indoor/Outdoor*
UNIT SIZE	6" x 24" 1sq.ft. .6"- 1.75" gauge
AVG. UNIT WEIGHT	12.5lbs.
SF. PER BOX	5 sq.ft.
PIECES PER BOX	5



Bluestone™



Charcoal™*



Mountain Rust™



Terracotta™

Color variations are inherent in all natural stone products. The product colors you see in this brochure are as accurate as current photography and printing techniques allow. We recommend you look at product samples before you select a color. * Moisture may cause this product to rust and effloresce. Pattern illustration is an approximation, actual stone layout may vary.

CLASSIC SERIES



Terracotta Accentstone Panels, Corners

ACCENTSTONE PANEL

Ideal for both small and large scale application Accentstone™ panels incorporate larger stones into each panel, for a more textured overall appearance. The panels have a smooth, linear finish, with a subtle amount of depth to bring interesting shadow play to the surface.

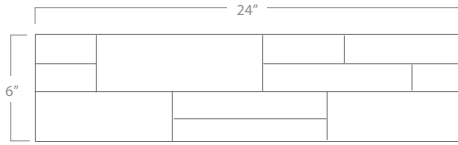

STONE TYPE	Slate, Quartzite
AVAILABLE COLORS	Bluestone, Charcoal, Sierra, Terracotta
FINISH	Split Face
MATCHING PRODUCTS	Corners, Ends, some Hearths
USAGE	Indoor/Outdoor*
UNIT SIZE	6" x 24" 1sq.ft. .8"- 1.5" gauge
AVG. UNIT WEIGHT	9.5lbs.
SF. PER BOX	6 sq.ft.
PIECES PER BOX	6



Bluestone™



Charcoal™*



Sierra™



Terracotta™

Color variations are inherent in all natural stone products. The product colors you see in this brochure are as accurate as current photography and printing techniques allow. We recommend you look at product samples before you select a color. * Moisture may cause this product to rust and effloresce. Pattern illustration is an approximation, actual stone layout may vary.

THINSTONE

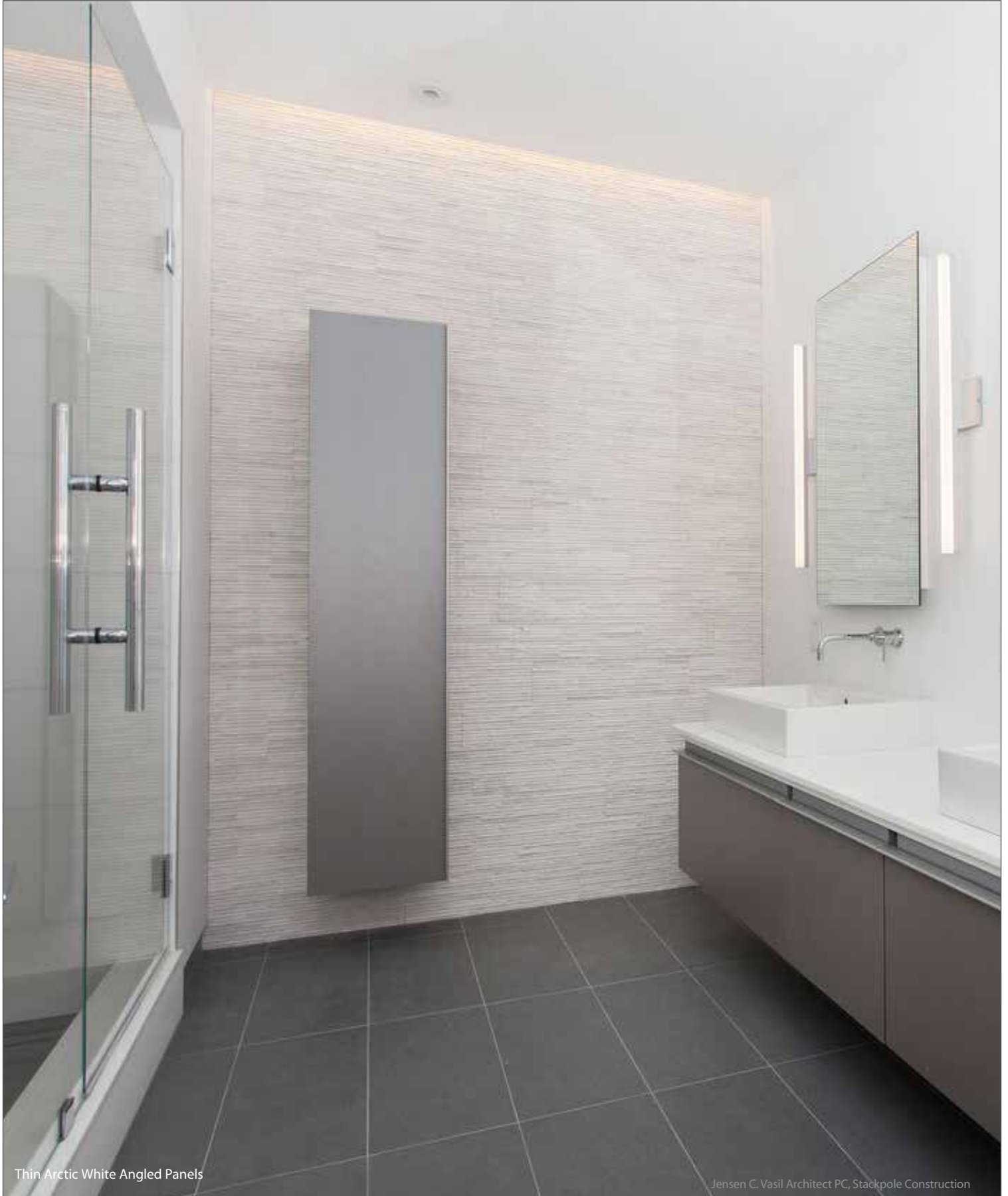

Thin Arctic White Angled Panels

Jensen C. Vasil Architect PC, Stackpole Construction

THINSTONE PANEL

Bring micro scale texture to your next project with Thinstone. Made of natural slate or quartzite cut in to ultra thin slices to form each panel. Available in a split face and a unique angled cut profile, the slim pieces of stone blend together into a subtle texture rich surface.

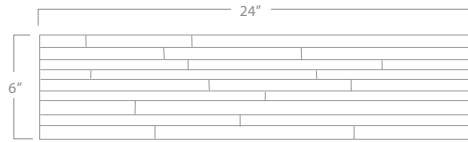

STONE TYPE	Slate, Quartzite
AVAILABLE COLORS	Silver Alabaster, Arctic White, Charcoal, Midnight Sky, Sierra, Terracotta
FINISH	Split Face, Angle Cut
MATCHING PRODUCTS	Corners, Ends, some Hearths
USAGE	Indoor/Outdoor*
UNIT SIZE	6" x 24" 1sq.ft. .8" - 1" gauge
AVG. UNIT WEIGHT	9.5lbs.
SF. PER BOX	6 sq.ft.
PIECES PER BOX	6



Thin Silver Alabaster Shadowstone™



Thin Arctic White Angled™



Thin Charcoal Shadowstone™*



Thin Midnight Sky Shadowstone™



Thin Sierra Shadowstone™



Thin Terracotta Shadowstone™

Color variations are inherent in all natural stone products. The product colors you see in this brochure are as accurate as current photography and printing techniques allow. We recommend you look at product samples before you select a color. * Moisture may cause this product to rust and effloresce. Pattern illustration is an approximation, actual stone layout may vary.



Estate Stone

Centuries of design tradition of old world European structures brought to life in a collection of premium natural stone veneers hand picked and crafted for simple elegance and timeless beauty.



Greystone Gold Estate Stone Panels & Corners

ESTATE STONE PANELS

Realstone Systems searched the globe for premium stone to create our Estate Stone products. Inspired by ancient European structures the panels have an impressive scale and regal appearance. The unique fingered panels are made of thick stone veneer pieces adhered to a stainless steel mesh for fast installation. A complete line of panels, corners and accessories make a full installation fast, easy and gorgeous.

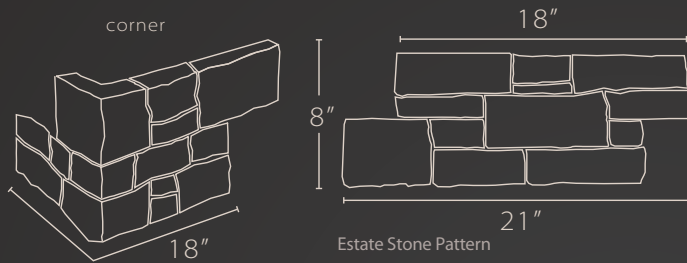

STONE TYPE	Quartzite, Granite, Slate	
AVAILABLE COLORS	Somerset Sage, Greystone Gold, Berkshire Buff, Bristol Black	
FINISH	Cleft Face	
MATCHING PRODUCTS	Corners, Hearths, Sills, Wall caps, Column Caps	
USAGE	Indoor/Outdoor	
STYLE	Panel	Corner
AVG. UNIT SIZE	18" x 8" 1 sq.ft. .8"-1.6" gauge	18" x 8" 1 sq.ft. .8"-1.5" gauge
AVG. UNIT WEIGHT	12-13lbs.	12-13lbs
AVG. SF. PER BOX	4 sq.ft.	4 sq.ft.
PIECES PER BOX	4	4



GREYSTONE GOLD™



BERKSHIRE BUFF™



BRISTOL BLACK™



SOMERSET SAGE™

Color variations are inherent in all natural stone products. The product colors you see in this brochure are as accurate as current photography and printing techniques allow. We recommend you look at product samples before you select a color. Pattern illustration is an approximation, actual stone layout may vary.

PORTUGAL

C O L L E C T I O N



Portugal Venato Tile

INSTALLATION SUGGESTIONS



PORTUGAL COLLECTION PANELS

The Portugal Collection panels are available in a dimensional surface similar to our Realstone™ Collection products as well as in a flat face option. The Panels come in sets of three patterns which can be used to create a multitude of patterns and styles. Paired with coordinating molding and trim pieces the Portugal Collection Panels provide a complete solution for striking natural stone applications.

STONE TYPE	Limestone, Marble	
AVAILABLE COLORS	Terra, Areia, Cinza, Venato	
FINISH	Various	
MATCHING PRODUCTS	Molding, Trim	
USAGE	Indoor	
STYLE	Dimensional Panel	Flat Panel
PANEL SIZE	12" x 4" .33sq.ft. 0.25" - .75" gauge	12" x 4" .33sq.ft. 0.25" gauge
AVG. PANEL WEIGHT	2.6 lbs.	1.9 lbs.
AVG. SF. PER BOX	6.67 sq. ft.	10 sq. ft.
PANEL PIECES PER BOX	20	30

PATTERNS (VARY PER BOX)

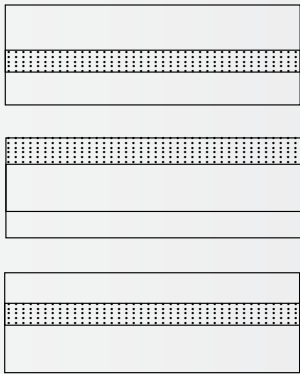

FACE: DIMENSIONAL

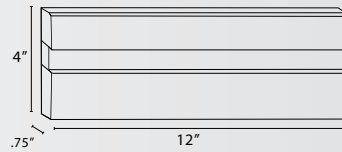

FACE: FLAT

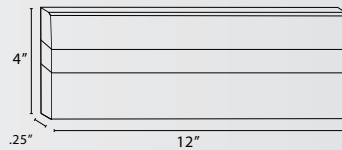

MOLDING & TRIM

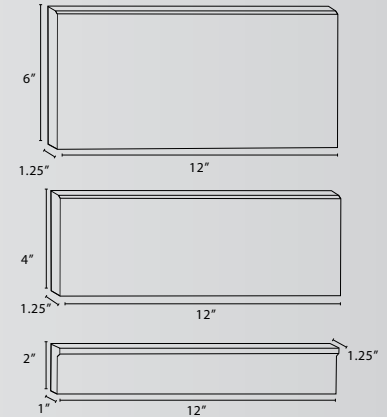

TERRA™ DIMENSIONAL



FLAT



CINZA™ DIMENSIONAL



FLAT



VENATO™ DIMENSIONAL



FLAT



AREIA™ DIMENSIONAL



FLAT



* All claims and technical information is provided by the Portugal manufacturer. Information is subject to change without notice.

Color variations are inherent in all natural stone products. The product colors you see in this brochure are as accurate as current photography and printing techniques allow. We recommend you look at product samples before you select a color.

HIVE

COLLECTION



Chiseled Cream, Barnwood and Driftwood Hive Tiles



Etched Hive Tile



Barnwood Hive Tile



Chiseled Hive Tile

HIVE TILES

Hive features a modern geometric design with deep relief patterns on hexagon shaped tiles of varying depths. The tiles are patterned in wood, chiseled stone and an etched linear pattern, fitting together to create a visually stunning display of endless geometry. Different patterns can be obtained by installing the two tile sets of convex and concave tiles or mixing the various colors. Hive tiles are made through a laboratory tested process, utilizing recycled marble and travertine.

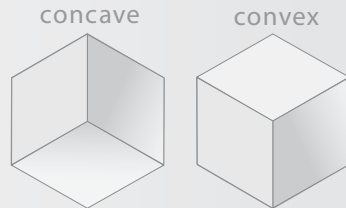

STONE TYPE	Travertine or Marble Dust + Resin	
FINISH	Wood Grain, Chiseled, Etched	
MATCHING PRODUCTS	Antique Wood Planks	
USAGE	Indoor/Outdoor	
AVAILABLE COLORS	Barnwood, Driftwood, Chiseled Cream	Etched Cream
UNIT SIZE	9.5" x 8.20" .54 sq.ft. 0.25"-1" gauge	10" x 8.625" .60 sq.ft. 0.25"-1" gauge
AVG. UNIT WEIGHT	concave 1.76 lbs. convex 3.52 lbs	concave 2.64 lbs. convex 4.84 lbs
AVG. SF. PER BOX	4 sq. ft.	4.5 sq. ft.
PIECES PER BOX	10 (5 convex, 5 concave)	10 (5 convex, 5 concave)

BARN WOOD™



DRIFT WOOD™



ETCHED CREAM™



CHISELED CREAM™



*All claims and technical information is provided by the Hive manufacturer. Information is subject to change without notice.

1. Barnwood and Driftwood products may temporarily produce an odor which will dissipate over time. 2. Product must not be installed in direct contact with heat source. Hive tiles are made of engineered marble and travertine stone which inherently lack uniformity and are subject to variations in aesthetics, color, shade, finish, tint, hardness, strength resistance, density, etc. These qualities are inherent in the nature of the product and are not to be considered latent defects. Realstone Systems does not provide installation services.

ANTIQUED WOOD PANELS

THE LOOK OF WOOD, THE DURABILITY OF STONE.



Driftwood Panel, Corner

ANTIQUUE WOOD PANELS

The life like appearance and texture of reclaimed wood in a maintenance free system that is water- resistant, non warping, non splintering and incredibly durable.

- Vertical Interior/external use, can be used in dry or wet conditions.
- Matching corner pieces.
- Easy to install panels are consistent in shape and size.
- Impervious to insects.
- Easy to clean.
- Does not splinter, warp or rot.
- No fire code issues.
- Does not fade.
- Low maintenance, doesn't require re-staining, sealing or ongoing up-keep.
- Made of recycled stone dust mixed with epoxy for a durable, non-porous material.

STONE TYPE	Travertine or Marble Dust + Resin	
AVAILABLE COLORS	Barnwood, Driftwood	
FINISH	Wood Grain	
MATCHING PRODUCTS	Hive Tiles	
USAGE	Vertical Indoor/Outdoor	
STYLE	Planks	Corner set
UNIT SIZE	22.75" x 11.875" 1.88sq.ft. 0.5" gauge	11.875" total height 0.5" gauge
AVG. UNIT WEIGHT	9 lbs.	2 lbs.
AVG. SF. PER BOX	11.3 sq. ft.	2 sq. ft. (3 linear feet)
PIECES PER BOX	6 panels	3 sets (15 individual pieces)

Panels



Corner Set



*All claims and technical information is provided by the Hive manufacturer. Information is subject to change without notice.
 1. Barnwood and Driftwood products may temporarily produce an odor which will dissipate over time. 2. Product must not be installed in direct contact with heat source.
 Antique Wood tiles are made of engineered Marble and Travertine stone which inherently lack uniformity and are subject to variations in aesthetics, color, shade, finish, tint, hardness, strength resistance, density, etc. These qualities are inherent in the nature of the product and are not to be considered latent defects. Realstone Systems does not provide installation services.

MORE THAN JUST GORGEOUS PRODUCTS WE OFFER INSTALLATION SOLUTIONS

Whether you start your Realstone project with panels or tile planks, and end with hearths or wall caps, we have all the pieces you need to complete your project. With all the components made from the same stone, it's easy to get a perfect match and a gorgeous installation.

PEWTER™

PEWTER HONED TILE PLANK 12"X24"



PEWTER HONED TILE PLANK 6"X24"



PEWTER HONED CORNER 6"X16" & 6"X8"



PEWTER HONED PANELS 6"X24"



PEWTER HONED HEARTH/WALL CAP 20"X20"



LATTE™

LATTE HONED TILE PLANK 12"X24"



LATTE HONED TILE PLANK 6"X24"

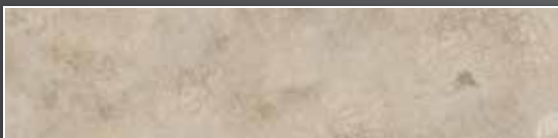

LATTE HONED CORNER 6"X16" & 6"X8"



LATTE HONED PANEL 6"X24"



LATTE HONED HEARTH/WALL CAP 20"X20"



BERKSHIRE BUFF™

GREYSTONE GOLD PANELS + BERKSHIRE BUFF HEARTH



BERKSHIRE BUFF WALL CAP 12"X30"



BERKSHIRE BUFF PANELS 8"X18"



BERKSHIRE BUFF SILL 3"X23.5"



BERKSHIRE BUFF CORNER 8"X18"



BERKSHIRE BUFF HEARTH 20"X20" COLUMN CAP 22"X22"



WHITE BIRCH™

WHITE BIRCH HONED TILE PLANK 12"X24"



WHITE BIRCH HONED TILE PLANK 6"X24"



WHITE BIRCH HONED CORNER 6"X16" & 6"X8"



WHITE BIRCH HONED HEARTH/WALL CAP 20"X20"



WHITE BIRCH HONED PANEL 6"X24"



WHITE BIRCH TILE PLANKS + WHITE BIRCH LEDGESTONE PANELS



ARCHITECTURAL ACCENTS

Realstone accessories are produced from the same natural stone source as Realstone panels and planks. Completing a project with Realstone accessories ties everything together and provides a finished, consistent look. The accessories are available in standard sizes and reduce cutting, waste, and labor. The result is a beautiful, seamless, natural stone installation. More images at www.realstone.com

CORNERS

Our pre built corners are time and labor savers. Standard panel corners come in two fingered pieces that fit neatly together for inside and outside corners. Estate stone corners are pre-built as one piece and Antique Wood corners come in 5 individual pieces that fit into the fingered ends of the panel.



Colors	Most panel colors			
Type	Description	Avg. Size	Avg. Gauge	Avg. Weight
Panel Corners	two fingered pieces that fit together	6"x16", 6"x 8"	0.5"- 2.0"	8.8-12 lbs.
Alesio Corners	two fingered pieces that fit together	6"x14", 6"x 10"	.37"-1.0"	8-9 lbs.
Estate Stone Corners	pre-built as one piece, stone on stainless steel mesh	13"x 5" x 8" *	0.8"- 1.5"	12-13 lbs.
Antique Wood Corners	5 piece set	11.875" total height	0.5"	2.67 lbs.

* approximate



NATURAL ENDS

Natural Ends are the solution for installations with an exposed edge. Each piece is finished on the two short ends. Natural End pieces can also be used as outside corners.

Colors	Most panel colors	
Avg. Size	Avg. Gauge	Avg. Weight
6" x 24"	0.5"- 2.5"	8.8-12 lbs.

HEARTHES & COLUMN CAPS

Hearths are commonly used for fireplaces, but can also be used as wall caps, or anywhere a thick, flat surface is needed. Column caps are a larger version of the hearths, with all 4 edges chiseled or split face.



Colors	Charcoal*, White Birch, Latte, Mocha Birch, Nero, Pewter, Greystone Gold, Bristol Black, Berkshire Buff, Spalted Oak, Creme, Smoky Beige		
Product and Finish	Avg. Size	Avg. Gauge	Avg. Weight
Column Cap- Estate Stone colors only 4 chiseled or split face edges, sandblasted top	22" x 22"	2.0"	95 lbs.
Hearth Type A- Collection & Alesio colors only 4 honed edges, honed top	20" x 20"	1.3"-1.6"	48.5-57 lbs.
Hearth Type B- Collection, Estate Stone, Charcoal 3 sawn edges, 1 chiseled, sandblasted or honed top	20" x 20"	1.3"-1.6"- Collection, Charcoal 1.89"-2.0" Estate	50-77 lbs.
Hearth Type C- Collection, Estate Stone, Charcoal 2 sawn edges, 2 chiseled, sandblasted or honed top	20" x 20"	1.3"-1.6"- Collection, Charcoal 1.89"-2.0" Estate	50-77 lbs.

* Moisture may cause this product to rust and effloresce.



WALL CAPS

Large pieces of stone perfect for finishing off fireplaces, landscape walls and many other projects.

Colors	Greystone Gold, Bristol Black, Berkshire Buff		
Product and Finish	Avg. Size	Avg. Gauge	Avg. Weight
2 sawn edges, 2 chiseled or split face edges, sandblasted top	30" x 12"	2.0"	71 lbs.

SILLS

Used as a finish around windows, fireplaces and anywhere a ledge, shallow shelf or trim is needed. Underside includes a drip edge.



Colors	Greystone Gold, Bristol Black, Berkshire Buff		
Finish	Avg. Size	Avg. Gauge	Avg. Weight
chiseled face edge, 3 sawn sides, sandblasted top	23.5" x 3"	1.89 - 2.0"	14 lbs.

Molding and Trim, Areia



PORTUGAL ACCESSORIES

Portugal tile projects can be finished off with a variety of accessories, for a complete installation solution.

Colors	Terra, Areia, Venato, Cinza			
Type	Description	Avg. Size	Avg. Gauge	Avg. Weight
Trim	beveled drip edge	2" x 12"	1.0"	2.2 - 2.4 lbs
Molding	beveled edge	6" x 12"	1.25"	7 - 7.65 lbs
Molding	beveled edge	4" x 12"	1.25"	4.73 - 5.14 lbs

Wall Cladding

Each panel measures 6" x 24" (one square foot)

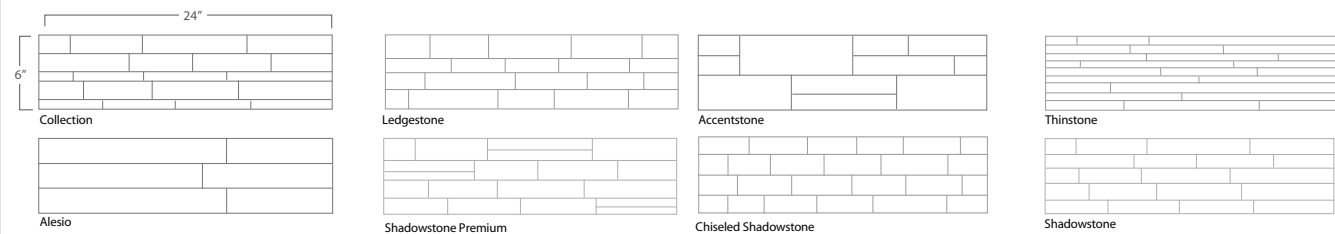

Stone Profiles	Finish	Rows Per Panel	Gauge	Avg. Weight	Units Per Box	Stone Type / Color	Granite	Travertine	Sandstone	Limestone	Slate	Quartzite	Marble	
Ledgestone	cleft face	4	0.6" - 1.75"	12.5lbs	5							Bluestone Charcoal Terracotta	Mountain Rust	
Shadowstone	split face	4-5	0.4" - 1.0"	8.8-10.4 lbs	6							Bluestone Charcoal Terracotta	Sierra Chiseled Sea Shell Midnight Sky Arctic White	
Accentstone	split face	4	0.8" - 1.4"	9.3 lbs	6							Bluestone Charcoal Terracotta	Sierra	
Thinstone	split face, angle cut	9-12	0.8" - 1.0"	9.5 lbs	6							Charcoal Terracotta	Sierra Arctic White Angled Midnight Sky	
Collection	honed, cleft face	4-5	0.4" - 1.0"	7.9-8.6 lbs	6			Nero	Latte	Mocha Birch	White Birch Pewter Carbon			
Alesio	honed, cleft face	3	0.34" - 1.0"	7.9-9 lbs	6-8				Spalted Oak					Crema Smoky Beige

Wall Cladding-Estate Stone, Portugal, Plank Tiles

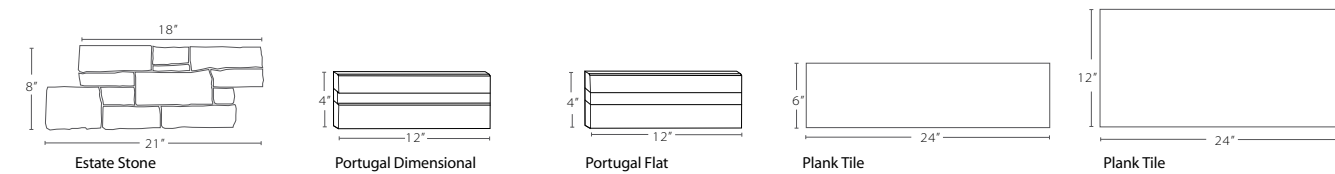

Stone Profiles	Size	Finish	Rows Per Panel	Gauge	Avg. Weight	Units Per Box	Stone Type / Color	Granite	Travertine	Sandstone	Limestone	Slate	Quartzite	Marble	
Estate Stone	8"x18" (1 sqft)	cleft face	4	0.8" - 1.6"	13.0 lbs	4			Bristol Black				Somerset Sage	Greystone Gold Berkshire Buff	
Portugal	4"x12" (0.33sqft)	dimensional	3	0.25"-0.75"	2.3-2.58 lbs	20						Areia Terra			Cinza Venato
		flat	3	0.25"	1.76-1.9 lbs	30									
Plank Tiles	6"x24" (1 sqft)	honed	NA	0.4"	5-5.5 lbs	10			Nero	Spalted Oak Latte	Mocha Birch	White Birch Pewter			Crema Smoky Beige
	12"x24" (2 sqft)			0.4"	9.8-11 lbs	5									

Antique Wood

Large panels with fingered ends

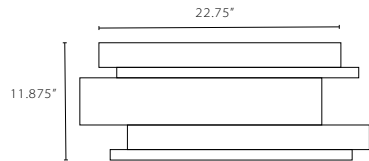

Hive Tiles

Come in pairs of concave and convex tiles

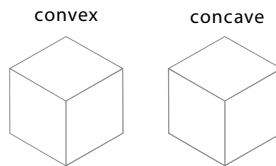

Stone Color	Size	finish	Stone Type	Avg. Gauge	Avg. Weight	Units Per Box	Stone Color	Size	finish	Stone Type	Avg. Gauge	Avg. Weight	Units Per Box
Driftwood Barnwood	22.75" x 11.875" (1.88 sqft)	wood grain	Stone dust and resin composite	0.5"	8 lbs	6	Barnwood Driftwood Chiseled Cream	9.5"x 8.20" (.54 sqft)	wood grain, chiseled	Stone dust and resin composite	concave 0.25"	concave 1.76 lbs	10
											convex 1"	convex 3.52 lbs	
							Etched Cream	10"x 8.625" (.60 sqft)	etched		concave 0.25"	concave 2.64 lbs	10
											convex 1"	convex 4.84 lbs	

2017 Realstone Systems, L.L.C. All rights reserved. Product availability subject to change without notice. The photography and color samples shown have been reproduced as accurately as our technology permits and are for representation only. To ensure the highest satisfaction, we strongly recommend you view an actual sample prior to ordering stone. Realstone stone products are made from natural stone found in nature. All natural stone products lack uniformity and are known to produce variation in color, texture, hardness, density and strength. It is common for natural stone to change its appearance over time due to exposure to weather, erosion, pollution or other factors beyond Realstone Systems, L.L.C.'s control. As a result, some characteristics that may occur include color tone change, release of minerals, flaking, cracking and chipping. Color bleeding may occur due to oxidation from mineral content of the stone. All products sold are with the understanding that these qualities are inherent in natural stone and are not to be considered latent defects. Realstone Systems, L.L.C. cannot be held liable in any cause of action and makes no expressed or implied warranty of merchantability or fitness for a particular purpose for any type of application. Natural stone is not suitable for all uses. Customer must determine appropriate use or fitness for a particular purpose for any natural stone products purchased. Realstone Systems, L.L.C. recommends that you consult with a professional installer to confirm that natural stone is right for your project. Realstone Systems, L.L.C. does not warranty damage caused by occurrences that are outside of our control such as improper installation, settlement, fire, acts of nature or natural characteristics of stone as outlined above.



www.Realstone.com | 866-698-5066
1170 Souter., Troy MI 48083 USA



Mark Sultana , DSDG Architects

Front and back cover: White Birch Honed Panels, Corners

ON OUR WEBSITE:

www.Realstone.com

- Live chat
- Huge photo gallery
- Inspirational photos and videos
- Installation tips
- Product calculator
- Custom Dealer Search
- Technical Information
- Visualizer

As seen on:



Member

